

## A Design of Single Phase Bridge Full-wave Rectifier

Sitaram Mahato, Naina Mohanty, Ipsita Pahi, Romeo Jena

Department of Electrical and Electronics Engineering, NM Institute of Engineering and Technology, Bhubaneswar, Odisha

Department of Electrical and Electronics Engineering, Raajdhani Engineering College, Bhubaneswar, Odisha

Department of Electrical and Electronics Engineering, Aryan Institute of Engineering and Technology Bhubaneswar, Odisha

Department of Electrical and Electronics Engineering, Capital Engineering College, Bhubaneswar, Odisha

**ABSTRACT:** This paper studies a characteristic of a single phase full wave rectifier. The rectifier has a single phase AC mains with 240 Vrms and 50 Hz frequency. The load is 220  $\Omega$  and the average output voltage can be varied from 5 V to 24 V. The output must get less than 1% voltage ripple. In this revision the ripple has to be under specified limit, and to get the ripple percentage limit, the method suggested in this paper is utilizing a capacitive filter circuit with bridge configuration.

**Keywords:** Bridge rectifier, fullwave rectifier, single phase, resistive load, voltage ripple.

### I. INTRODUCTION

AC power is available at low cost. DC power is more expensive to produce; therefore a method of changing ac to dc is needed as an inexpensive dc source. AC power can be converted to DC power using rectifiers. When ac power is converted to dc power using rectifiers, dc output contains unwanted alternating current components known as ripple. Many rectifier applications need that the ripple do not exceed a specified value. If the ripple exceeds the specified value, different unwanted effects appear in the system. Some of the unwanted effects are stray heating and audible noise. The ripple can be reduced using an output filter (Pyakuryal&Matin, 2013a).

### II. LITERATUREREVIEW

There are two types of single-phase full-wave rectifier, namely, full-wave rectifiers with center-tapped transformer and bridge rectifiers (Rashid, 2011). The chosen method in this paper is bridge rectifier as shown in Figure 1. The outputs of the two half-wave rectifiers are combined to produce full-wave rectification in the load. As far as the transformer is concerned, the dc currents of the two half-wave rectifiers are equal and opposite, such that there is no dc current for creating a transformer core saturation problem. The voltage and current waveforms of the full wave rectifier are shown in Figure2.

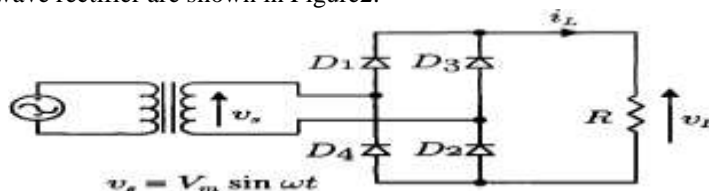

Figure 1: The single phase bridge full wave rectifier

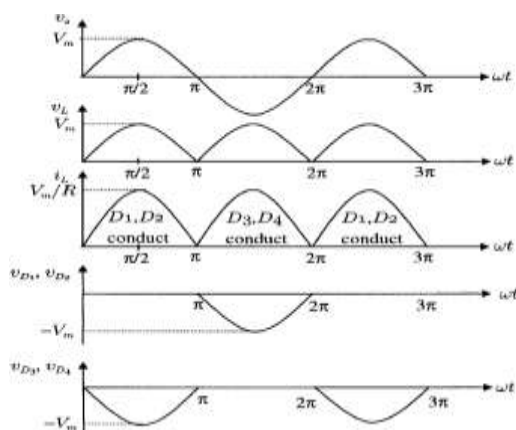

Figure 2: Voltage and current of single phase bridge full wave rectifier

The average value of the load voltage  $V_L$  is  $V_{dc}$  and it is defined as:

$$V_{dc} = \frac{1}{T} \int_0^T V_m(t) dt \quad (\text{Eq.1})$$

The angular frequency of the source  $\omega = 2\pi/T$ , and equation (1) can be rewritten as:

$$V_{dc} = \frac{1}{2\pi} \int_0^{2\pi} V_m \sin(\omega t) d(\omega t) \quad (\text{Eq.2})$$

In the case of a full-wave rectifier, for both the positive and negative half-cycles calculate by neglecting the negative and assume it as positive cycle. Hence, equation (2) can be simplified as:

$$V_{dc} = \frac{2V_m}{\pi} \quad (\text{Eq.3})$$

The root-mean-square (rms) value of load voltage,  $V_L$  is  $V_o$ , which is defined as:

$$V_o = \sqrt{\frac{1}{T} \int_0^T v_m^2(t) dt} \quad (\text{Eq.4})$$

In the case of a half-wave rectifier, for the negative half-cycle, therefore, equation (4) can be rewritten as:

$$V_o = \sqrt{\frac{1}{\pi} \int_0^{\pi} (V_m \sin(\omega t))^2 d(\omega t)} \quad (\text{Eq.5})$$

Therefore;

$$V_o = \frac{V_m}{\sqrt{2}} \quad (\text{Eq.6})$$

The average value of load current  $I_L$  is  $I_{dc}$  and because load R is purely resistive it can be found as:

$$I_{dc} = \frac{V_{dc}}{R} \quad (\text{Eq.7})$$

simplified from equation (3) and (7), so that:

$$I_{dc} = \frac{0.636 V_m}{R} \quad (\text{Eq.8})$$

Based on equation (6) and (7), results:

$$I_o = \frac{0.707 V_m}{R} \quad (\text{Eq.9})$$

The ripple factor is a ratio of the rms value of ripple voltage  $V_{rms}$  to the average value of output voltage as shown in equation (10) (Pyakuryal & Matin, 2013a).

$$\% \text{ripple} = \frac{V_{rms}}{V_{ave}} \times 100\% \quad (\text{Eq.10})$$

## 2.0 Voltage design consideration

The goal in practical design is to achieve a given dc output voltage, in this case is 5V to 24V. Therefore, it is more convenient to put all the design parameters in terms of  $V_{dc}$ . For example, the rating and turns ratio of the transformer in a rectifier circuit can be easily resolute if the rms input voltage to the rectifier is in terms of the required output voltage  $V_{dc}$  (Rashid, 2011). Represent the rms value of the input voltage to the rectifier as  $V_{rms}$ , which is equal to  $0.707 V_m$ . the rms input voltage per secondary winding of a full-wave rectifier is initiate as:

It is important to evaluate the Peak Repetitive Forward Current (IFRM) rating of the employed diodes in rectifier circuits. In the case of full-wave rectifiers, Full-wave IFRM.

$$V_{rms} = 1.11 V_{dc} \tag{Eq.11}$$

Another important design parameter is the Peak Repetitive Reverse Voltage (VRRM) rating of the diodes employed. In the case of a bridge rectifier:

$$V_{RRM} = \frac{V_{dc}}{0.636} \tag{Eq.12}$$

It is important to evaluate the Peak Repetitive Forward Current (IFRM) rating of the employed diodes in rectifier circuits. In the case of full-wave rectifiers, Full-wave IFRM.

$$I_{RRM} = \frac{I_{dc}}{0.636} \tag{Eq.13}$$

### 2.1 Capacitance output filter design consideration

Placing a large capacitor parallel with the load may produce the output voltage that is essentially direct current (Hart,2011). In the full wave circuit , the time that capacitor discharge is smaller than that for the half wave circuit because of the rectified sine wave in the second half of each period (Fraser & Milne, 1994).By using an output filter, if a capacitor is used through the load and an inductor is used in series with the load, the load current will be smoother and ripple effect will be lowered (Pyakuryal&Matin,2013b).

Then, to get the smooth the output of the rectifier a tank capacitor is used - placed across the output of the reciter and in parallel with the load. This capacitor charges up when the voltage from the rectifier increases above that of the capacitor and then as the rectifier voltage falls, the capacitor offers the required current from its stored charge (Pyakuryal&Matin,2013b). The Figure 3 below shows the ripple for a full wave rectifier with capacitor smoothing. For cases where the ripple is small compared to the supply voltage - which is almost always the case - it is possible to calculate the ripple from a knowledge of the circuit conditions (Hart, 2011).

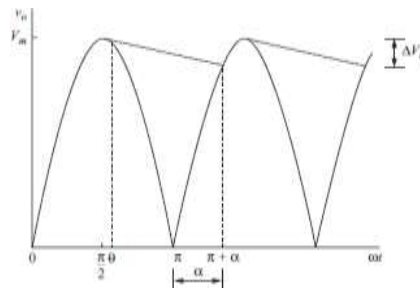

Figure 3: The ripple ( $\Delta V_o$ ) in single phase bridge full wave rectifier

As mentioned by Mulkern, Henze and Lo (1991) and Raymond et. al (2003), there will always be some ripple on the output of a rectifier using a smoothing capacitor circuit, it is necessary to be able to guess the approximate value. Over- specifying a capacitor too much will add extra cost, size and weight - under-specifying it will lead to poor performance.

Based on Hart (2011), the approximation, the peak-to-peak ripple is:

$$V_o = \frac{V_m}{\omega RC} = \frac{V_m}{2fRC} \tag{Eq.14}$$

So that, the voltage ripple ratio is:

$$\frac{\Delta V_o}{V_m} = \frac{1}{2fRC} \tag{Eq.15}$$

Then, the value of the capacitor can be written as:

$$C = \frac{1}{\frac{\Delta V_o}{V_m} 2fR} \tag{Eq.16}$$

These equations provide more than sufficient accuracy. Although the capacitor discharge for a purely resistive load is exponential, the inaccuracy introduced by the linear approximation is very small for low values of ripple (Hart, 2011).

### III. METHODOLOGY

#### 3.1 The Design of Bridge Full Wave Rectifier

The design of this rectifier is divided to three steps, involve the setting of transformer ratio to get the right value at secondary winding. Then, the ripple percentage without the smoothing capacitor calculated. The last stage, the value of smoothing capacitor calculate by considering the ripple magnitude. The simulation done to ensure the requirement fulfilled.

#### 3.2 Setting the transformerratio

Firstly, the dc output 24 V at the load is chosen. The turns ratio of the transformer (Hart, 2011) is shown in equation (17).

$$\text{Turns\_Ratio} = \frac{V_{\text{Primary}}}{V_{\text{Secondary}}} = \frac{N_{\text{primary}}}{N_{\text{secondary}}} \quad (\text{Eq.17})$$

#### 3.3 Calculating the ripple percentage without capacitivefilter.

Hence, the  $V_{\text{rms}}$  at secondary coil is 24V, replacing the value in equation (3) as below:

$$V_{\text{ave}} = V_{\text{dc}} = \frac{2V_m}{\pi}$$

By substitute the average value to equation (10), the ripple percentage of the rectifier is:

$$\% \text{ripple} = \frac{24}{21.6} \times 100\% \text{ so that } \% \text{ripple} = 111.11\%$$

#### 3.4 Calculating the capacitorvalue

Peak to peak ripple is get from the derivation of equation (14), (15) and (16) get the value of capacitance:

$$0.01 = \frac{24}{2(50)(220)C}$$

$$C = 4.545 \text{ mF}$$

#### 3.5 Calculating ripple percentage with smoothing capacitor

By using the value of smoothing capacitor, the ripple percentage calculated by getting the charge removed from the capacitor during the discharge cycle ( $\Delta Q$ ) and the load current. (Rawlins, 2000):

$$I_{\text{load}} = \frac{V_{\text{ave}}}{R_L} \quad (\text{Eq.18})$$

The charge removed from the capacitor during the discharge cycle is:

$$\Delta Q = I_{\text{load}} T \quad (\text{Eq.19})$$

The relation between the  $V_m$  and  $\Delta Q$  is:

$$V_m = \frac{\Delta Q}{C} \quad (\text{Eq.20})$$

Solving the equation (20) and (10), the ripple percentage is:

$$\% \text{ripple} = \frac{42.08m}{21.6} \times 100\% \text{ , so that } \% \text{ripple} = 0.197\%$$

#### IV. RESULTS AND DISCUSSION

After that, the simulation using Multisim 14 provided by National Instrument was done to get the rectification output.

##### 4.1 Without Capacitor

The schematic of the single phase bridge full wave rectifier is shown in Figure 4, the waveform of the circuit is represented in Figure 5.

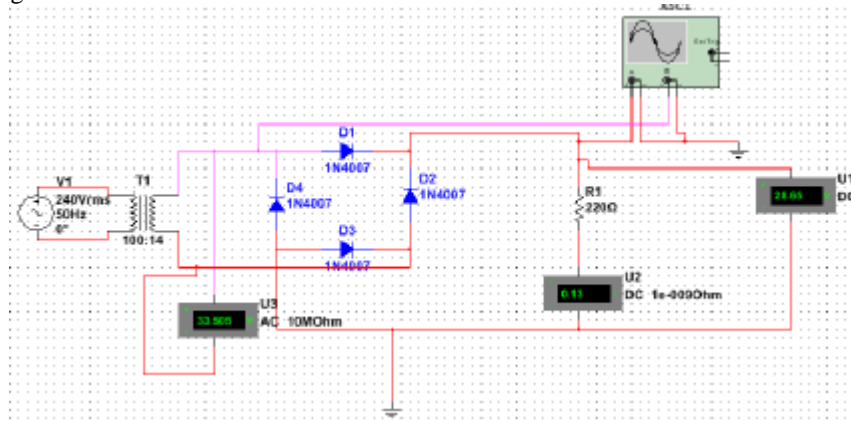

Figure 4: Single phase bridge full wave resistive load rectifier

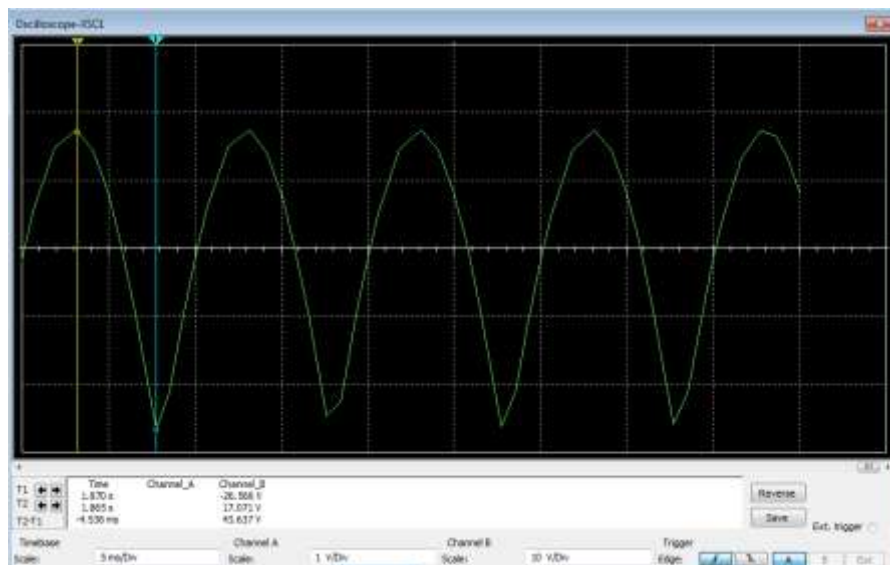

Figure 5: The waveform of single phase bridge full wave resistive load rectifier The ripple percentage of Figure 3.2 based on equation (Eq.10) circuit is:

$$\%ripple = \frac{43.63}{22.92} \times 100\% , \text{ so the result is } \%ripple = 190.39\% .$$

##### 4.2 With Capacitor

Then, the smoothing capacitor is placed in parallel with the load (Figure 6), the ripple is shown in red line in Figure 7.

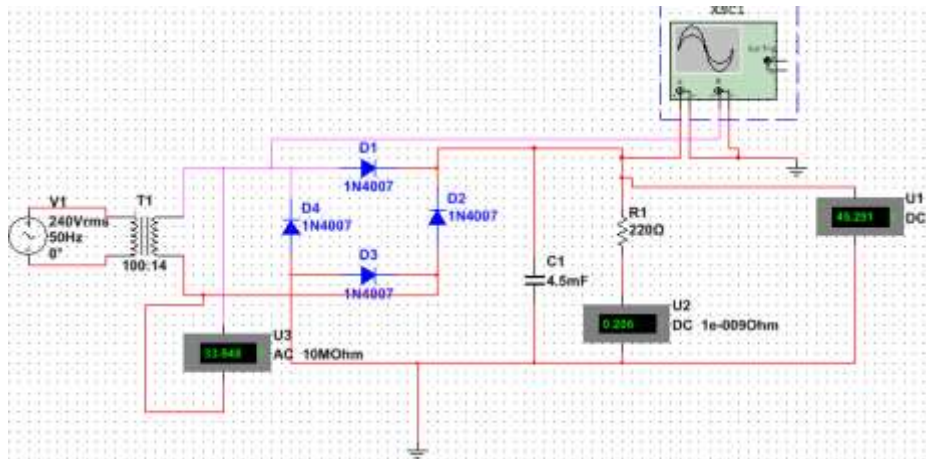

Figure 6: Single phase bridge full wave resistive load rectifier with capacitor filter

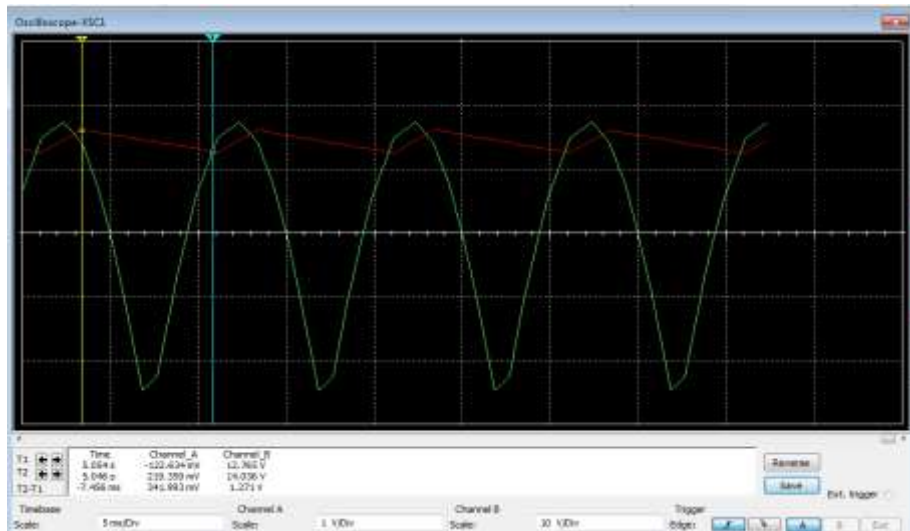

Figure 7: The waveform of single phase bridge full wave resistive load rectifier with capacitor filter The ripple percentage of Figure 6 circuit is:

$$\%ripple = \frac{341.993m}{22.92} \times 100\% , \text{ so the } \%ripple = 1.49\%$$

## V. CONCLUSIONS

Based on the calculation and simulation, the summary of these two approaches as shown in Table 1.

**Table 1:** Comparison of calculation and simulation of single phase bridge full wave resistive load rectifier with capacitor filter

The characteristic	Calculation	Simulation
V <sub>m</sub>	33.94	33.505
V <sub>load</sub> (rms)	23.99	28.65
V <sub>load</sub> (dc)	21.6	22.92
%ripple (without C)	111.11%	190.39%
%ripple (with C)	0.197%	1.49%

Then the Table 2 summarized the design that can be implemented to get the various dc output from 5V to 24 V (approximately values) at the resistive load.

**Table 2:** The turn's ratio of transformer to get the varied dc output of single phase bridge full wave resistive load rectifier with capacitor filter

Vdc	Vrms	C	%ripple (with C)	Turns ratio
5	6	4.545mF	1.0897%	100:3
10	12	4.545mF	1.029%	100:5
15	17	4.545mF	2.405%	100:8
20	24	4.545mF	1.282%	100:12
25	28	4.545mF	1.355%	100:14

The bridge full wave rectifier with a capacitor filter was designed to achieve the specified ripple percentage. It has been shown that the effective control of ripple can be achieved by choosing proper values of capacitor for a filter in AC to DC rectifier, and the required dc voltage can be acquired by using the correct value of turns ratio.

### REFERENCES

- [1]. Fraser, C., & Milne, J. (1994). *Electromechanical Engineering: An Introduction*: Chicago: IEEE Press.
- [2]. Hart, D. W. (2011). *Power Electronics*: New Delhi: Tata McGraw-Hill.
- [3]. Pyakuryal, S., & Matin, M. (2013a). Filter Design for AC to DC Converter. *International Refereed Journal of Engineering and Science*, 2(6), 42-49.
- [4]. Pyakuryal, S., & Matin, M. (2013b). Ripple Control in AC to DC Converter. *IOSR Journal of Engineering*, 3(1), 26-30.
- [5]. Rashid, M. (2011). *Power Electronics Handbook*: Pensacola Florida: Elsevier Science.
- [6]. Rawlins, C. (2000). *Basic AC Circuits*: Woburn Massachusetts: Elsevier Science.